

MOT - Multi Output Terminal

Terminal data sheet

The Dialock Multi Output Terminal (MOT) is based on the Dialock terminal firmware of version 7. In general it is compatible to a standard WT in following features:

- Compatible to the Dialock system:
 - Stand Alone
 - SA+
 - Hotel (without individual guest room support)
 - Clinic (without individual guest room support)
 - Universal (without individual guest room support)
 - Personnel
 - Online system (Personnel, Hotel)
- Multikey support: Up to 4 logical keys on one transponder
- Macro programmable
 - MOT specific macros supported by DMD V 1.15 or higher
- Extended Personnel Key (XPK)
- Easy configuration with Special Function Transponders
- More comfortable configuration with Parameter Transponders
- Diagnostic parameters
- Only one firmware for TIRIS, LEGIC and Tag-It/ISO version because of separated, intelligent reading unit
- Key stamps for realising usage count/check
- Output timers for realising output activation in a sort of "multi-tasking"
- SA IDs
- Firmware-support of LC-Display (not supported by standard hardware)
 - LCD can be macro programmed
- Optional support of multiple reading units at one control unit

Differences to a standard TV7 wall terminal

- No toggle mode for relay1 on main control unit
- No personnel 4-eyes principle
- No cash function
- No individual guest door support
- No "Do not disturb" function (DND)
- No in-system flash support (only standard boot loader)
- No support of time zone modes or options (automatic lock/unlock)
 - Time zones are only supported by MOT rules and Macros

Principle of access rights at the MOT

The general access rights of the MOT are configured according to the corresponding Dialock system:

- SA system:
Learning SA keys
- Personnel system:
Personnel group configuration with Personnel software and transfer of data by one of the following options:
 - Service software and MDU
 - Service software online or with MDU IR-dongle
 - Parameter key
- Hotel system
Setting guest options by one of the following options:
 - Service software and MDU
 - Service software online or with MDU IR-dongle
 - Parameter keyOptionally the guest key validation can be done generation-controlled. But this should only be done when it can be ensured that nearly all guest really use the terminal. Otherwise the generations may not be actualized and are not valid when more than 10 guests in a row are not using the terminal!

The configuration of the access rights for floors or special elevator functions (e.x. priority or emergency switches) is based on rules. A rule has following parameters:

- Range of outputs / relay switches (elevator: floors) for which the rule applies.
It has to be a coherent range - no gaps are allowed. When there are gaps then an additional rule with another range is needed.
- Access condition of rule
There are following possible conditions:

SA Key - ID numbers SA ID number has to be within a given range (0..32767).	SA system
Guest keys - Room number Guest key number has to be within a given range of room numbers (1..9999)	Hotel system
Guest key- Room / key number (not at elevator terminal) Guest room and key numbers have to be identical with the given values Room number: 1..999 Key number: 1..4	Hotel system with multiple occupation (e.x. clinics)
Guest keys - Option flag (standard) At least one of the specified guest options has to be set. The value is interpreted bitwise.	Hotel system
Guest keys - Option value Value of guest key option has to be within a specified range (0..63)	Hotel system
Visitor keys - Option flag At least one of the specified guest options has to be set.	Hotel system
Maintenance keys Maintenance key number has to be within a given range of room numbers (1..9999).	Hotel system
Personnel keys - Key number Key number has to be within a given range (1..30000).	Personnel system
Personnel keys - Group number Group number has to be within a given range (0..250). 0 stands for "no group rights".	Personnel system
Personnel keys - Option number Personnel option number has to be within a given range (0..255).	Personnel system
Personnel keys - XPK number (XPK = Extended Personnel Key) XPK number has to be within a given range (0..1023).	Personnel system
Personnel keys - privileged Personnel key must have the specified privilege	Personnel system
Any valid key Any valid key (SA, Hotel or Personnel) matches this condition	any Dialock system
Any key (incl. invalid) Any readable transponder matches this condition	any Dialock system

Time zone start Condition gets true once at start of specified time zone	any Dialock system
Time zone end Condition gets true once at end of specified time zone	any Dialock system
During time zone (all 15s) This rule action is done every 15 seconds when specified time zone is valid	any Dialock system
Digital input condition State of digital inputs must have a specified pattern	any Dialock system
Macro rule definition This rule condition can be activated by macro program. There can be up to 255 different rules to be activated by macro (Macro State Set #31). With this rule it is possible to set the specified outputs to another open time than the standard open time or to set them to special lock states	any Dialock system

- Time zone condition of the rule
 There is no time condition
 or
 actual time has to be within one of the 4 time zones
- Action to perform when rule is valid
 This specifies the relays contact state

1	off
2	on
3	cycle (with standard open time)
4	toggle

The rules are stored together with the keys in the key memory of the terminal. Each rule needs as much memory as one key (8 bytes).

Operation of OTX (output extender) outputs and LEDs

All output contacts are operated by independent timers when cycling. This means that another contact can be activated by another access condition as soon as one contact was activated. A timer is "retriggered" by activating the MOT again by a valid access rule. This means that the cycle time begins again by each activation.

The output timers have a duration tolerance of max. -1 sec dependent on the moment of start of activation.

So it is good practice to define the opening time at least 1 second longer than needed.

The LEDs at the reading unit are switched as follows:

A general access right of a key is signaled by inverting the green LED state for 30ms.

When at least one OTX output is activated for the specified open time then the green LED is switched on for that time. Permanently activated outputs (e.x. toggled outputs) are not shown by green LED.

The LED control can be deactivated by macro program with the macro "STATE SET main control LEDs = 0".

An output which is toggled open is not changed by another rule which cycles the output.

An output which is set to "open" is not changed by another rule which cycles the output.

When a MOT system is restarted after shutdown (e.g. power failure) the former state of the relay contacts is set.

Operation of relays on MOT control unit

Optionally the first 4 outputs can be directed to the 4 relays on the main control unit. For this the parameter "Main relays" has to be set.

Outputs 5-8 are then not available and output 9 is the first output on OTX1, output 10 the second output on OTX1 and so on...

Special Function transponders

Following special function transponders are specific for MOT:

0x10: Test OTX

With this special function transponder the MOT can be tested by four different test modes:

1. "Running light" (OTX outputs are activated sequentially).
Speed appr. 2 Hz
2. Blinking (OTX outputs are alternating all activated / all deactivated).
Speed appr. 2 Hz

3. Alternate blinking (OTX outputs are all toggling their state with alternating states of all outputs).
Speed appr. 2 Hz
4. Switch all outputs to active state.

Each time reading the special function transponder the terminal is switched to the next test mode.

0x37: Test Locking

Test locking includes operation of all OTX outputs.

The amount of switched OTX is dependent on the configured number of OTX (standard is 16 OTX with 128 outputs). If configured the relays on main control unit are operated as OTX1.

Simple Reset

Simple reset sets the state of all relays contacts to inactive and resets the project code to 815.

Default settings after total reset

The MOT has identical reset default parameters for all transponder-technologies: TIRIS, ISO-TagIt, LEGIC.

- Output activation time: 5 sec.
- SA system
- Main control unit relays are used
- Relays configured as NO (normally open)
- No "wait for gone"
- 150 audit trail entries with 3761 keys / rules
- Reading 4 multikeys
- Project code: 815
- Number of OTX: 16
- Guest access option 255 (all guest key options valid)
- General guest terminal without generation control

Opentime for "Cycle" operation

The maximum open time is 240 sec. Higher values may cause errors.

Standard time is 5 sec.

Audit trail

Audit trail entries are made without report of the lock state because this cannot be specified for all relay outputs. So the audit trail only reports the usage of keys - not which or if any output contacts were activated.

MOT specific configuration parameters

- **Relay NC**
This parameter has to be set when relays with NC contacts are used.
When activated all relay output states are inverted:

Relay NC (normally closed) Invert OTX output active states	Output inactive state	Output active state
Parameter not checked (standard)	Relay not powered	Relay powered
Parameter checked	Relay powered	Relay not powered

- **Use main relays**
Use relays on main control unit as OTX 1
By setting this parameter the first 4 outputs are redirected to the 4 relays on the main control unit. The outputs 5-8 are not available then.
Beginning with output 9 all following outputs are on OTX1 and further cascaded OTX.
- **Number of OTX**
The the number of connected OTX has to be set.
The maximum number is 16, the minimum number is 1.
When the relays on the main control unit are used then this counts as one OTX.

MOT configuration

Additionally to the standard configuration with terminal parameters the MOT has to be configured by acces rules, which are stored in the terminals key list. These rules data has to be created with the MOT Configuration software.

The most comfortable way to configure a MOT is to do it with a terminal data base by the Dialock Service software. The configuration data can then be tranfered to the terminal by MDU (1.0.6 or higher) or by online connection.

There is following alternative possibility to configure a MOT after defining the configuration with the MOTCONFIG program:

- Export the MOT rules to a DPK file
- Load this file into the key list menu in Dialock Service software (PC Beam menu).
- Then the rules can be transferred by online connection to the MOT or can be programmed to a parameter transponder (max. 15 rules)

MOT macro programming

Following macros are specific for the MOT:

Macro	Command ID	Parameter	Function
Do Action	#82	-	Sets output extender according to the bits of VAR1
Do Action	#83	-	MOT buffer to OTX Set OTX to actual state of buffer
State Set	#31	MOT macro rule ID (0..255)	Set buffer according to specified macro rule
State Set	#32	0: All off 1..240: Open time 252: Toggle 253: Off locked 254: On locked 255: On permanently	Sets complete buffer to specified value. State is set in buffer. To take place at outputs the macro Do Action #83 must be called.

State Set	#33	0: Off 1..240: Open time 252: Toggle 253: Off locked 254: On locked 255: On permanently	MOT set output specified by VAR1 to specified value. VAR1: 0..127, 0 is first output. State is set in buffer. To take place at outputs the macro Do Action #83 must be called. Toggle does not change outputs with "locked" state (253, 254).
---------------------------	---------------------	--------------------------------------------------------------------------------------------------------	------------------------------------------------------------------------------------------------------------------------------------------------------------------------------------------------------------------------------------------------------------

Data

Max. keys / rules at 150 audit trail entries: 3761

Max. opening time: 240 sec.

Max. number of outputs: 128 + 4

Max. number of inputs: 4

Max. number of relay outputs (elevator: floors) by rules: 128

System requirements

For configuration of the MOT following Dialock system components are required:

- Dialock MDU 1.1.7 or higher
- Dialock Service 2.3.0 or higher
- DMD 1.15 or higher (optional)
- MOT configuration software (MOTCONFIG)

Hardware wiring diagrams

MOT main control unit

Connection Diagram Control Unit SWS-21 WT-OTX

Power Supply:

8 - 36 VAC / 9 - 40 VDC

"Total" Software Reset:

Actuation of reset-button longer than 4 seconds until the red LED stops flashing.

"Simple" Software Reset:

Actuation of reset-button between 1 and 4 seconds. Release the reset-button while the red LED is flashing

Firmware-Update:

connect the ISP contacts,
Simple Software Reset,
Download via RS-232 Interface

Inputs:

IN1 - IN4 optically decoupled
5VDC - 24VDC
ATTENTION: regard polarity!

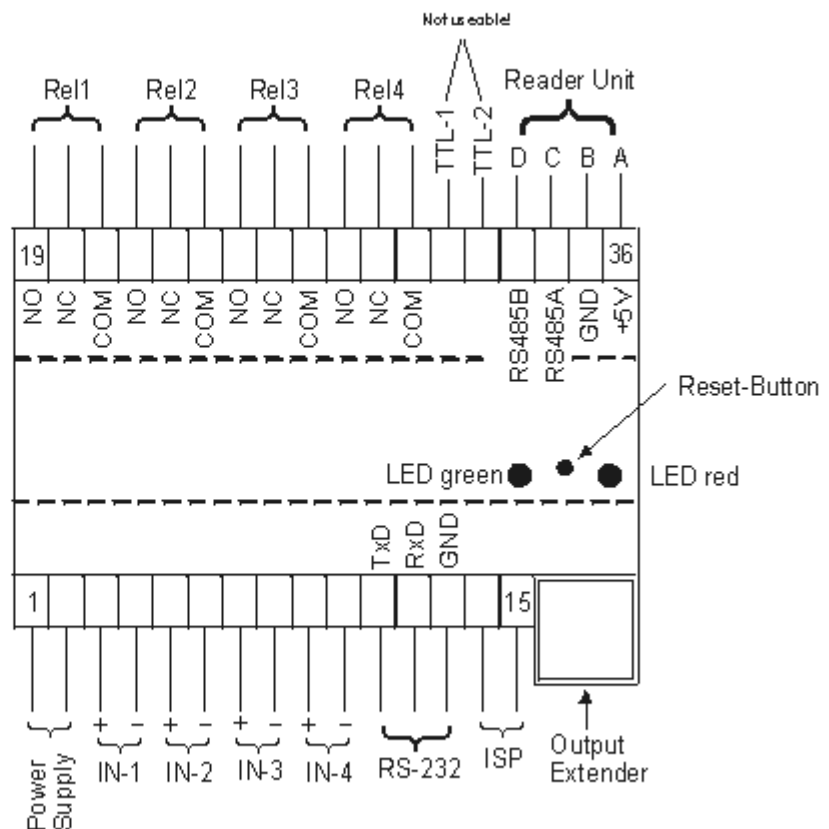

SPX 29.06.04
C.Meier

Connections at OTX

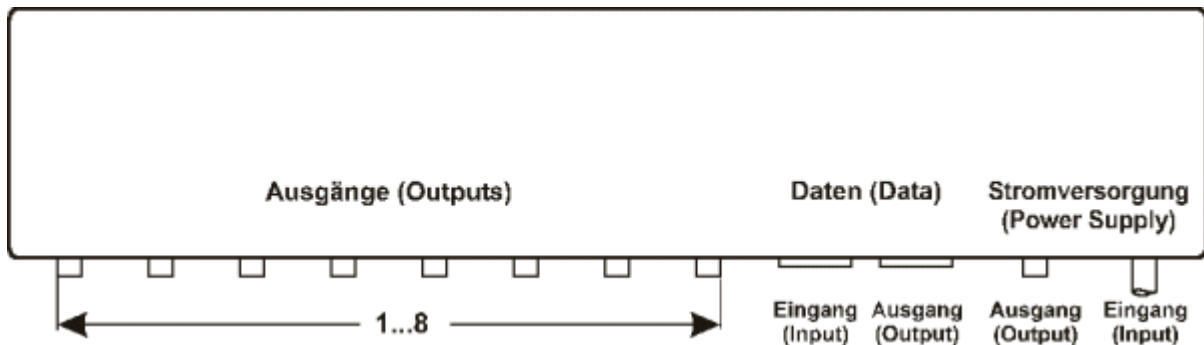

Schematic of MOT wiring

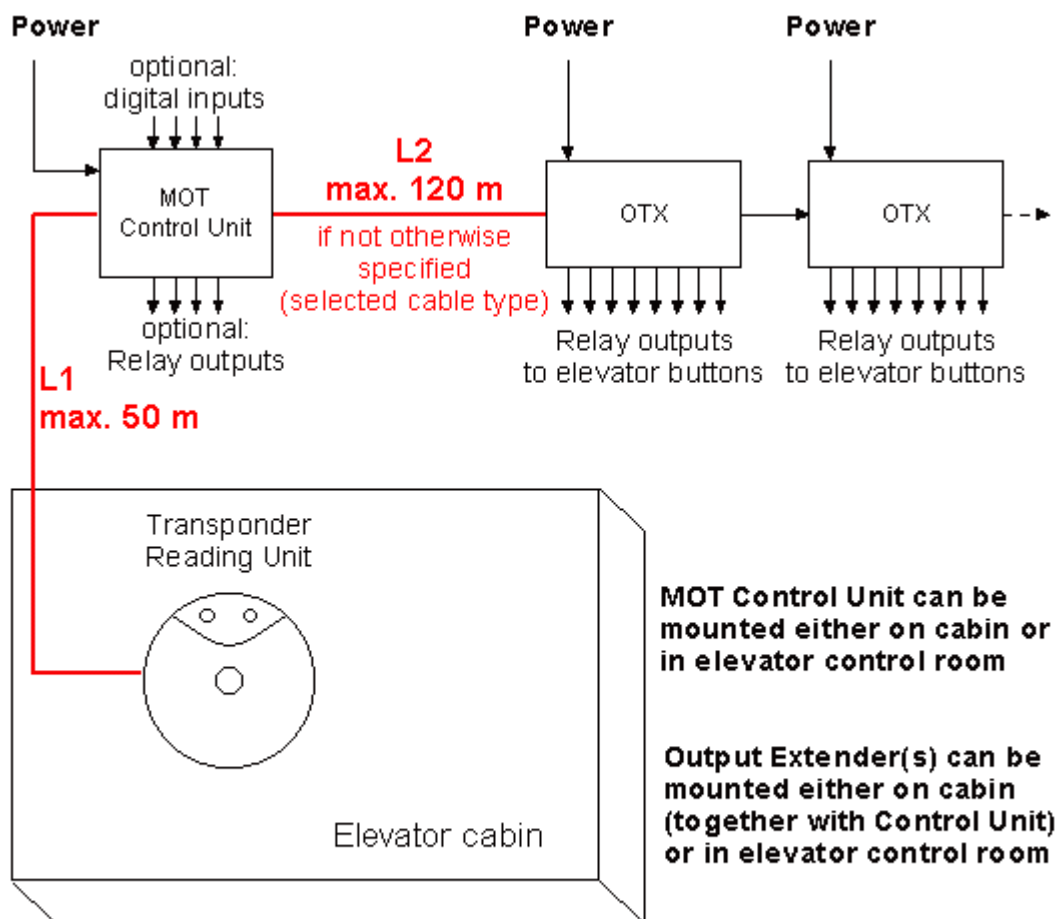



DET - Dialock Elevator Terminal

A special application of the MOT is the access control for floors in an elevator. In this application the MOT is also named as Dialock Elevator Terminal (DET).

The Dialock Elevator Terminal (DET) is designed for controlling access to the floor select buttons of an elevator. When a key is presented to the DET reader inside the elevator cabin then all by Dialock authorized floors select buttons are enabled by relays.

The DET consists of following components:

- Transponder Reading Unit (TIRIS, LEGIC or ISO/TagIt)
Optionally a DET can be operated with up to 4 reading units
- MOT Control Unit
Optionally the 4 relays of this control unit can be used
- optional: Up to 16 Output Extenders (OTX)
Each OTX can be connected to max. 8 floor selection buttons.
In total the DET is able to control the access of max. 128 floors.

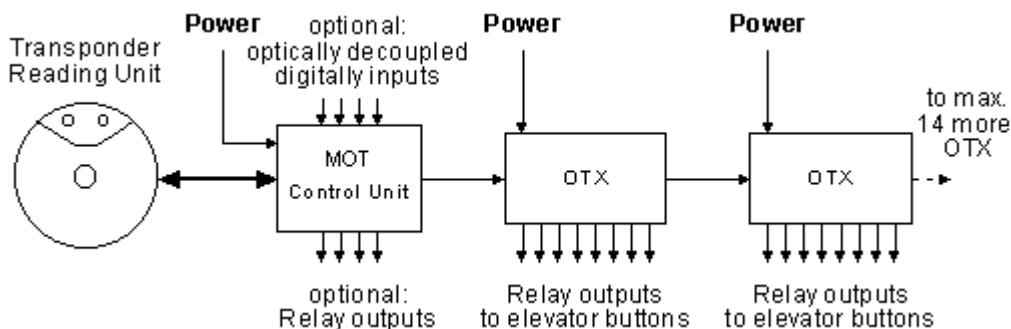

The positioning of Transponder Reading Unit, the Control Unit and the Output Extender(s) depends on the space available in cabin and on the location of the elevator control room. The cable type and length has to be carefully selected.

Dependent on the application the relays of the OTX can be connected in parallel or in serial to the floor selection buttons. To fall into a save state in case of failure of the DET an appropriate wiring to relay contacts should be done:

Enabling of floor select button by DET

When presenting a key to DET all floor select buttons are enabled to which the owner of the key has access rights. The user has to press the floor button to select his wanted destination floor.

Enabled on DET failure

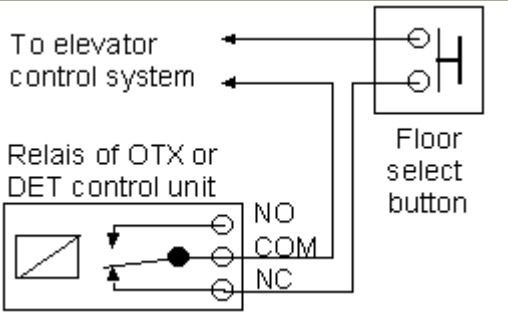
	<p>The relay is connected in serial to the floor select button.</p> <p>The OTX must have the "NC relay" option. The DET has to be configured to "NC relay".</p> <p>This is a fail-save configuration: On DET failure the elevator can still be operated.</p>
-----------------------------------------------------------------------------------	----------------------------------------------------------------------------------------------------------------------------------------------------------------------------------------------------------------------------------------------------------------------

Disabled on DET failure

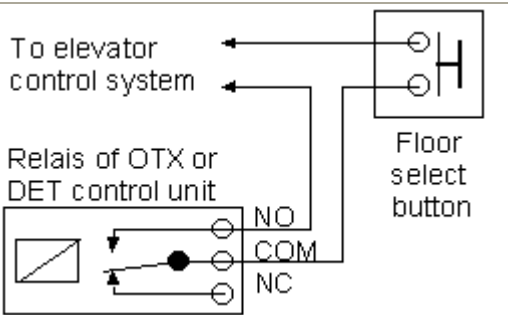
	<p>The relay is connected in serial to the floor select button.</p> <p>The OTX must have the "NO relay" option. The DET has to be configured to "NO relay".</p> <p>On DET failure the elevator cannot be operated.</p>
-------------------------------------------------------------------------------------	----------------------------------------------------------------------------------------------------------------------------------------------------------------------------------------------------------------------------

Activation of floor select button by DET

When presenting a key to DET then the floor button is directly activated by DET. This operation is only possible when each person has access right to only one floor and the ground floor needs no identification.

The floor access buttons in the elevator cabin have to be deactivated or replaced by "mechanical lock switches".

Enabled on DET failure

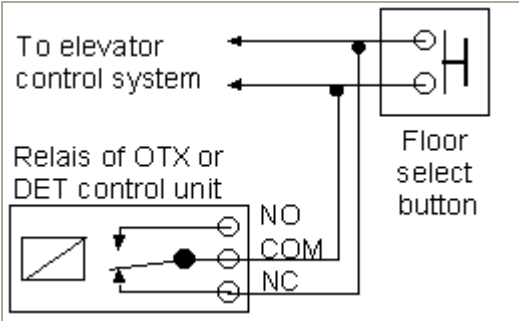
 <p>To elevator control system</p> <p>Relais of OTX or DET control unit</p> <p>Floor select button</p> <p>NO COM NC</p>	<p>The relay is connected parallel to the floor select button.</p> <p>The OTX must have the "NC relay" option. The DET has to be configured to "NC relay".</p> <p>On DET failure all buttons are activated.</p>
------------------------------------------------------------------------------------------------------------------------------------------------------------------------------------------------------------------	---------------------------------------------------------------------------------------------------------------------------------------------------------------------------------------------------------------------

Disabled on DET failure

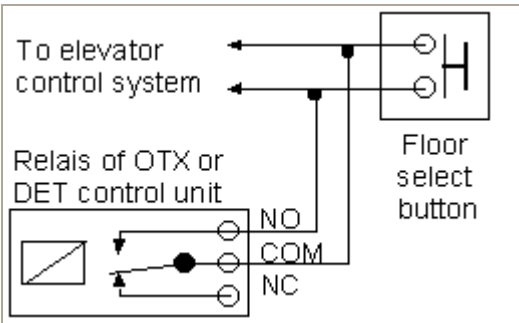
 <p>To elevator control system</p> <p>Relais of OTX or DET control unit</p> <p>Floor select button</p> <p>NO COM NC</p>	<p>The relay is connected parallel to the floor select button.</p> <p>The OTX must have the "NO relay" option. The DET has to be configured to "NO relay".</p> <p>On DET failure no manual operation is possible, because the floor select buttons are deactivated.</p>
-------------------------------------------------------------------------------------------------------------------------------------------------------------------------------------------------------------------	-----------------------------------------------------------------------------------------------------------------------------------------------------------------------------------------------------------------------------------------------------------------------------

Access Configuration of DET

The basic access rights have to be configured according to the required Diallock access system.

A key is checked for the following properties:

- Hotel/Clinic/Universal:
Option Bits, expiration date/time, project code
- Personnel system
Group rights, generation, individual right, expiration date, time zone, project code
- SA
Key code in memory

When a key has access right then the DET decides which relays have to be switched by checking the so called "DET Rules". These rules are defined with the DET Configuration Software. A DET can have more than 2000 rules (depends on number of keys in memory). A rule defines the following conditions:

A specified range of relays is set when all following conditions are true:

- Key is of the required type
(e.x. guest key room number range, personnel key number range ...).
- Specified time zone is valid (zone 1..4 or always)

MOT Configuration software

The MOT configuration software is installed together with the Dialock Service software (Dialock Service 2.3.0 or higher).

It can be started directly or it can be started by Dialock Service for comfortabel configuration of a MOT in the terminal data base.

The program MOTCONFIG is for definition and visualisation of MOT access rules. MOTCONFIG creates a parameter definition file (.DRC) and a rules definition file (tag file xxx-21.TTAG). These files are located always in the TDAT directory.

Multi Output Terminal Configuration

How to configure an MOT in the Dialock System?

The most comfortable way is the configuration with Dialock Service by creating a terminal data base and transferring the terminal configuration by MDU to the terminals.

1. Start and configure Dialock Service
Set language, data path, COM-Port and further necessary data in the settings menu of Service software.
2. Login
3. Set up a terminal categories data base
Here you have to define a categorie with terminal type **MOT** for the elevator terminal.
4. Optional: Set up a terminal parameter data base
If necessary you have to define terminal parameter sets for all terminals with special settings.
For the DET you do not have to do this here (but you can). Instead the MOT configuration software will create a MOT parameter set automatically later (see 6.)

5. Set up a terminal data base
The MOT has to be defined in the terminal data base with the according terminal categorie (with terminal type MOT).
When a MOT terminal is selected in terminal list then the "MOT button" appears.
6. Define the DET parameters and access rules definition.
Click the DET button and select "*** New ***" (or select an existing MOT configuration)
7. Make all definitions in the MOTCONFIG software and close it.
Now a terminal parameter set **MOTxxx** and a tag file **xxx-21** is assigned to the MOT in the terminal data base list. xxx is an automatically generated number for the elevator configuration.
8. Optional: Change specific parameter settings in terminal parameter data base for MOT.
If you have to set special parameters which are not handled by the MOTCONFIG software (e.x. guest options, ignore expiring date ...) then you can go to the parameter data base menu und change the settings in the according MOT parameter set (MOTxxx).
9. Optional: Online transfer of MOT configuration.
When the MOT has an online connection and the terminal data base entry of the MOT has the correct online setting then you can transfer the MOT configuration by clicking the online button to the terminal. All parameter settings, macros (if present) and access rules (tag files) are transferred but NOT the personnel group definition.
10. The complete MOT configuration can now be transfered to the MOT and then to the terminal.

On later changes on MOT rules or other MOT configuration a newly tranfer of the configuration with MDU can be done without loss of actually valid key data in the MOT (personnel keys).

DET - Dialock Elevator Terminal

Application Example

Following a description of requirements for an elevator terminal in a hotel. It is a hotel with 25 floors and special access rights for guests and personnel with time zones.

Floors 1 - 5:

Everybody can access these floors by pressing one (or more) of the buttons 1 to 5. No time restrictions.

Floors 6 - 19, 24 and 25:

In the time between 06:00 and 22:00 everybody can access these floors by pressing one (or more) of the buttons 6 - 19, 24 and 25.

In the time between 22:00 and 06:00 guests have to present their Key to the reader. After presenting the Key the button of the corresponding floor is activated automatically. It is not possible to go to a different floor than the "own" one (out of 6-19,24,25) at night time (22:00-06:00).

Floor 22:

This Floor can be accessed by any valid guest key by presenting the Key AND then pressing the button "22". This is for all times (24 hours).

Floor 20, 21, 23:

These floors can only be accessed by guests that have valid keys for one of these floors. The guest has to present the Key to the reader AND then choose one (or more) floor out of 20, 21, 23 by pressing the corresponding button. This is for all times (24 hours).

All Staff (Personnel) Keys have access to all floors. During the day time to the floors 6-19,24,25 by just pressing the corresponding button, to all other times and all other floors by presenting their valid personnel Key AND then choose a floor by pressing the corresponding button.

DET configuration for these requirements

Following basic settings have to be done:

- 25 floors require 4 OTX
- No usage of relays on main control unit
- NO (normally open) relays are used
- Hotel and Personnel system
- Relay activation time is 5 sec.
- One time zone is used (any day 6:00 until 22:00)
- All relay contacts are named with the according floor number

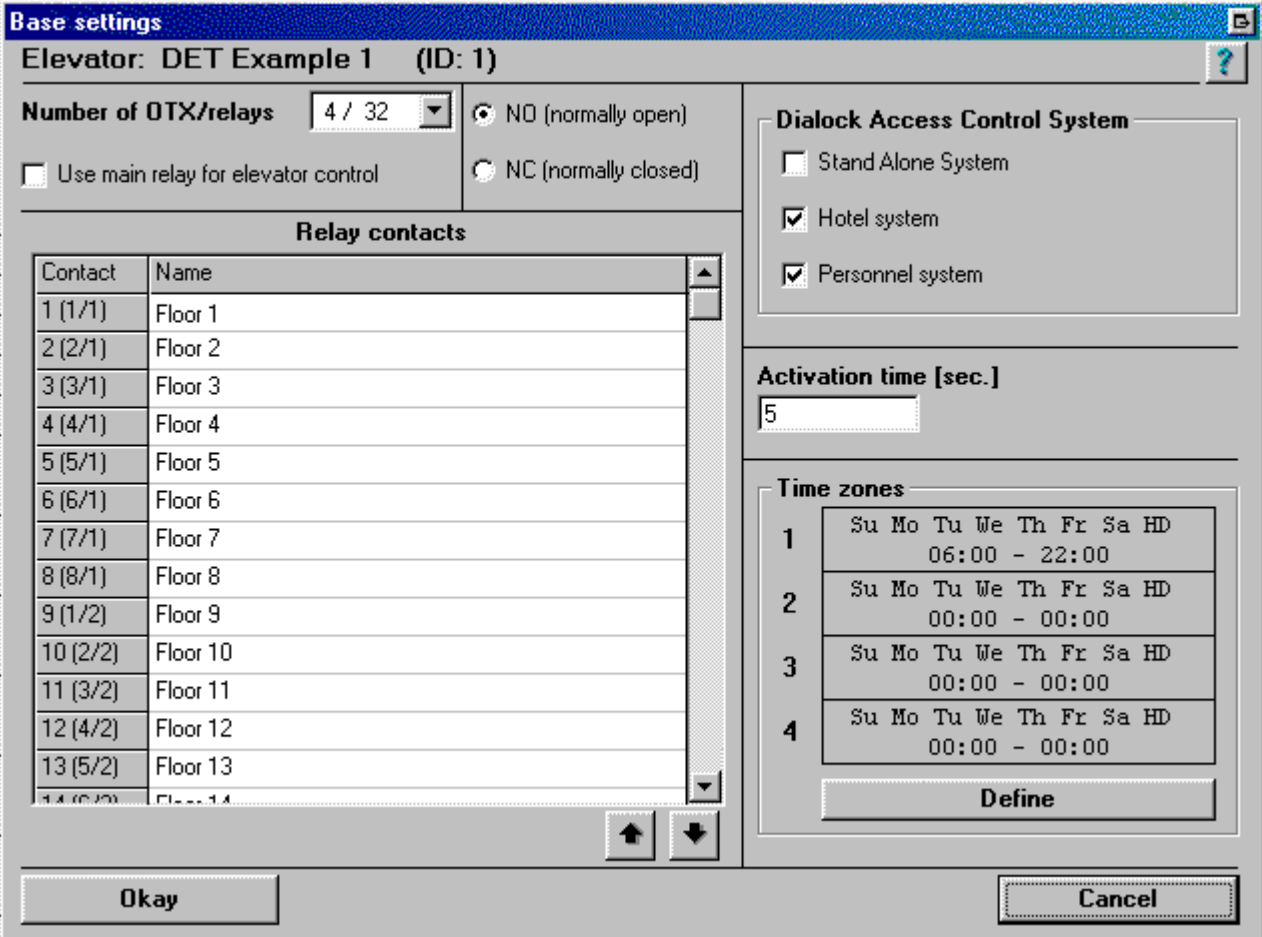

Base settings
Elevator: DET Example 1 (ID: 1)

Number of OTX/relays: 4 / 32

NO (normally open)
 NC (normally closed)

Use main relay for elevator control

Relay contacts

Contact	Name
1 (1/1)	Floor 1
2 (2/1)	Floor 2
3 (3/1)	Floor 3
4 (4/1)	Floor 4
5 (5/1)	Floor 5
6 (6/1)	Floor 6
7 (7/1)	Floor 7
8 (8/1)	Floor 8
9 (1/2)	Floor 9
10 (2/2)	Floor 10
11 (3/2)	Floor 11
12 (4/2)	Floor 12
13 (5/2)	Floor 13
14 (6/2)	Floor 14

Dialock Access Control System

Stand Alone System
 Hotel system
 Personnel system

Activation time [sec.]
5

Time zones

	Su	Mo	Tu	We	Th	Fr	Sa	HD
1								06:00 - 22:00
2								00:00 - 00:00
3								00:00 - 00:00
4								00:00 - 00:00

Define

Okay Cancel

Configuration of relay switches

All floor select buttons of the elevator are connected in serial to the OTX relay contacts. Although floors 1 to 5 do not require an access control they should also be wired because this allows easy changes of access rights later. So the relays for floors 1 to 5 have to be enabled all the time. All other floors have key and time dependent access rules.

Dialock Elevator Terminal Configuration
 Program Elevator View ?

DET Example 1 (ID: 1) Base settings

ID	Contact	Name	Access rule	Action	Time zone
1	1 / 1	Floor 1	During time zone (all 15s)	On	Always
2	2 / 1	Floor 2			
3	3 / 1	Floor 3			
4	4 / 1	Floor 4			
5	5 / 1	Floor 5			
6	6 / 1	Floor 6	Personnel keys - Key number 00001-30000	Cycle	1: Su Mo Tu We Th Fr Sa HD 06:00-22:00
			Guest keys - Room number 0601-0699	Off	
			Time zone start	On	
7	7 / 1	Floor 7	Personnel keys - Key number 00001-30000	Cycle	Always
			Guest keys - Room number 0701-0799	Off	
			Time zone start	On	
8	8 / 1	Floor 8	Personnel keys - Key number 00001-30000	Cycle	Always
			Guest keys - Room number 0801-0899	Off	
			Time zone start	On	
9	1 / 2	Floor 9	Personnel keys - Key number 00001-30000	Cycle	Always
			Guest keys - Room number 0901-0999	Off	
			Time zone start	On	

View: Rules Relays Show unused

Buttons: Add, Delete, Change, Print, Exit

Dialock Elevator Terminal Configuration
 Program Elevator View ?

DET Example 1 (ID: 1) Base settings

ID	Contact	Name	Access rule	Action	Time zone
20	4 / 3	Floor 20	Guest keys - Room number 2101-2199	On	
			Guest keys - Room number 2301-2399		
21	5 / 3	Floor 21	Personnel keys - Key number 00001-30000	Cycle	Always
			Guest keys - Room number 2001-2099		
			Guest keys - Room number 2101-2199		
22	6 / 3	Floor 22	Guest keys - Room number 2301-2399	On	
			Guest keys - Room number 2201-2299		
23	7 / 3	Floor 23	Personnel keys - Key number 00001-30000	Cycle	Always
			Guest keys - Room number 2001-2099		
			Guest keys - Room number 2101-2199		
24	8 / 3	Floor 24	Guest keys - Room number 2301-2399	On	1: Su Mo Tu We Th Fr Sa HD 06:00-22:00
			Personnel keys - Key number 00001-30000		
			Guest keys - Room number 2401-2499		
25	1 / 4	Floor 25	Time zone start	On	1: Su Mo Tu We Th Fr Sa HD 06:00-22:00
			Personnel keys - Key number 00001-30000	Cycle	
			Guest keys - Room number 2501-2599	Off	

View: Rules Relays Show unused

Buttons: Add, Delete, Change, Print, Exit

Dialock Elevator Terminal Configuration
Program Elevator View ?

DET Example 1 (ID: 1) Base settings

ID	Contact	Name	Access rule	Action	Time zone
19	3 / 3	Floor 19	Time zone start	On	1: Su Mo Tu We Th Fr Sa HD 06:00-22:00
			Time zone end	Off	
20	4 / 3	Floor 20	Personnel keys - Key number 00001-30000	Cycle	Always
		Guest keys - Room number 2001-2099			
		Guest keys - Room number 2101-2199			
		Guest keys - Room number 2301-2399			
21	5 / 3	Floor 21	Personnel keys - Key number 00001-30000	Cycle	Always
		Guest keys - Room number 2001-2099			
		Guest keys - Room number 2101-2199			
		Guest keys - Room number 2301-2399			
22	6 / 3	Floor 22	Guest keys - Room number 2201-2299	Cycle	Always
		Personnel keys - Key number 00001-30000			
		Guest keys - Room number 2001-2099			
		Guest keys - Room number 2101-2199			
23	7 / 3	Floor 23	Personnel keys - Key number 00001-30000	Cycle	Always
		Guest keys - Room number 2001-2099			
		Guest keys - Room number 2101-2199			
		Guest keys - Room number 2301-2399			
24	8 / 3	Floor 24	Personnel keys - Key number 00001-30000	Cycle	Always
		Guest keys - Room number 2401-2499			
		Time zone start	On		
		Time zone end	Off		

View: Rules Relays Show unused

Buttons: Add, Delete, Change, Print, Exit

Following the main window with the "rule view mode":

Dialock Elevator Terminal Configuration
Program Elevator View ?

DET Example 1 (ID: 1) Base settings

Rule	Relay conta	Access rule	Action	Time zone
12	14	Guest keys - Room number 1401-1499	Cycle	Always
13	15	Guest keys - Room number 1501-1599	Cycle	Always
14	16	Guest keys - Room number 1601-1699	Cycle	Always
15	17	Guest keys - Room number 1701-1799	Cycle	Always
16	18	Guest keys - Room number 1801-1899	Cycle	Always
17	19	Guest keys - Room number 1901-1999	Cycle	Always
22	20 - 21	Guest keys - Room number 2001-2099	Cycle	Always
23	23	Guest keys - Room number 2001-2099	Cycle	Always
24	20 - 21	Guest keys - Room number 2101-2199	Cycle	Always
25	23	Guest keys - Room number 2101-2199	Cycle	Always
1	22	Guest keys - Room number 2201-2299	Cycle	Always
26	20 - 21	Guest keys - Room number 2301-2399	Cycle	Always
27	23	Guest keys - Room number 2301-2399	Cycle	Always
18	24	Guest keys - Room number 2401-2499	Cycle	Always
19	25	Guest keys - Room number 2501-2599	Cycle	Always
2	6 - 25	Personnel keys - Key number 00001-30000	Cycle	Always
28	6 - 19	Time zone end	Off	1: Su Mo Tu We Th Fr Sa HD 06:00-22:00
29	24 - 25	Time zone end	Off	1: Su Mo Tu We Th Fr Sa HD 06:00-22:00
20	6 - 19	Time zone start	On	1: Su Mo Tu We Th Fr Sa HD 06:00-22:00
21	24 - 25	Time zone start	On	1: Su Mo Tu We Th Fr Sa HD 06:00-22:00

View: Rules Relays Show unused

Buttons: Add, Delete, Change, Print, Exit

Access rule

Relay contacts

5 / 01	Floor 5
6 / 01	Floor 6
7 / 01	Floor 7
8 / 01	Floor 8
1 / 02	Floor 9
2 / 02	Floor 10
3 / 02	Floor 11
4 / 02	Floor 12
5 / 02	Floor 13
6 / 02	Floor 14
7 / 02	Floor 15
8 / 02	Floor 16
1 / 03	Floor 17
2 / 03	Floor 18
3 / 03	Floor 19
4 / 03	Floor 20
5 / 03	Floor 21
6 / 03	Floor 22
7 / 03	Floor 23
8 / 03	Floor 24
1 / 04	Floor 25
2 / 04	Relay 2/4 (not used)
3 / 04	Relay 3/4 (not used)
4 / 04	Relay 4/4 (not used)
5 / 04	Relay 5/4 (not used)

Access right

Guest keys - Room number

Access right for all guest keys in the given room number range (1..9999)

2001 until 2099

0113 (ID=GR0113):	Gastraum113
0114 (ID=GR0114):	Gastraum114
0115 (ID=GR0115):	Gastraum115
0116 (ID=GR0116):	Gastraum116
0117 (ID=GR0117):	Gastraum117
0118 (ID=GR0118):	Gastraum118
0119 (ID=GR0119):	Gastraum119
0120 (ID=GR0120):	Gastraum120

Time zone

Always

Relay function

Cycle

?, Okay, Cancel

Access rule

Relay contacts

1 / 01	Floor 1
2 / 01	Floor 2
3 / 01	Floor 3
4 / 01	Floor 4
5 / 01	Floor 5
6 / 01	Floor 6
7 / 01	Floor 7
8 / 01	Floor 8
1 / 02	Floor 9
2 / 02	Floor 10
3 / 02	Floor 11
4 / 02	Floor 12
5 / 02	Floor 13
6 / 02	Floor 14
7 / 02	Floor 15
8 / 02	Floor 16
1 / 03	Floor 17
2 / 03	Floor 18
3 / 03	Floor 19
4 / 03	Floor 20
5 / 03	Floor 21
6 / 03	Floor 22
7 / 03	Floor 23
8 / 03	Floor 24
1 / 04	Floor 25

Access right

Personnel keys - Key number

Access right for all Personnel keys in the given number range (1..30000)

1 until 30000

00001:	Diallock MASTER
00010:	Key No. 10

Time zone

Always

Relay function

Cycle

?, Okay, Cancel

Access rule

Relay contacts		Access right
1 / 01	Floor 1	Time zone start
2 / 01	Floor 2	Action at the beginning of the given time zone
3 / 01	Floor 3	
4 / 01	Floor 4	
5 / 01	Floor 5	
6 / 01	Floor 6	
7 / 01	Floor 7	
8 / 01	Floor 8	
1 / 02	Floor 9	
2 / 02	Floor 10	
3 / 02	Floor 11	
4 / 02	Floor 12	
5 / 02	Floor 13	
6 / 02	Floor 14	
7 / 02	Floor 15	
8 / 02	Floor 16	
1 / 03	Floor 17	
2 / 03	Floor 18	
3 / 03	Floor 19	
4 / 03	Floor 20	
5 / 03	Floor 21	
6 / 03	Floor 22	
7 / 03	Floor 23	
8 / 03	Floor 24	
1 / 04	Floor 25	

Time zone: 1: Su Mo Tu We Th Fr Sa HD 06:00-22:00

Relay function: On

Buttons: All, None, ?, Okay, Cancel